

**I. INTRODUCTION**

Thank you for choosing your Xantrex Alternator Regulator (XAR) multi-stage regulator. This regulator has been designed to maximize the charging efficiency of your DC system, and can be used with many P-type, externally regulated alternators.

The XAR is designed to provide superior charge control for most common battery types. Both models are pre-programmed at the factory for universal, “out-of-the-box” operation with most batteries. Built-in selectable programs for Deep-Cycle Lead Acid, AGM, Gel and Optima battery types are also available on both regulator models. In addition, the XAR provides an Amp Manager for precise alternator output control. Manual equalization, required for some battery types, is available. Data ports, for use with future optional remote displays, are included on both regulators.



The XAR can monitor and compensate for alternator over-temperature conditions when combined with optional alternator temperature sensor (XAR-TS-A). The XAR also has the ability to monitor and compensate for under- or over-temperature conditions at one battery, when equipped with optional battery temperature sensor (XAR-TS-B). Maximum temperature compensated voltage is 14.8 volts.

**CAUTION**

*The following instructions are intended for use by experienced marine electrical installers. If you are not experienced at installing electrical system components, we recommend the use of a qualified marine electrical technician.*

**II. INSTALLATION**

1. Mount the regulator in a dry, well-ventilated place. Avoid installation in areas of excess heat and/or vibration. Avoid locations where regulator or wiring connections could be exposed to water or coolant.
2. If not pre-connected at the factory, attach the inline, fourplex plug to the regulator (see **Figure 1**). Connect the second ground wire (**BLACK**) to the Independent Ground terminal. See **Figure 6**.
3. The **BROWN** (ignition) wire activates the regulator. Attach the **BROWN** wire to a switched +12VDC source. The ignition switch or an independent (ungrounded) oil pressure switch are both acceptable connection points. A toggle switch may be added to this circuit to shut down the alternator manually when increased propulsion is needed.
4. Attach the **RED** wire as close to the battery as possible. Likely connections include: 1) at the positive battery terminal (single battery bank), 2) at the common side of a battery selector switch (multi-battery banks), or 3) at the alternator’s positive output. The **RED** wire enables the regulator to monitor battery voltage -- and must always see the battery being charged. When using an isolator, the **RED** sense wire **MUST** connect on one of the isolator's output terminals. If using a dual-output alternator, the **RED** wire must connect to one of the alternator output posts. If battery banks are unequal in size, we recommend the **RED** wire be connected at the larger battery bank.

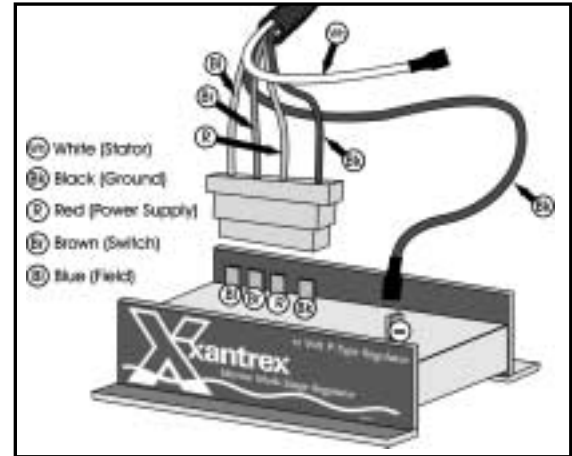

**Figure 1 - Regulator wiring harness.**

**TABLE OF CONTENTS**

<p><b>I. Introduction</b> .....1</p> <p><b>II. Installation</b> .....1</p> <p><b>III. Operation</b> .....3</p> <p><b>IV. Programming for Battery Type</b> .....3</p> <p><b>V. Advanced Programming</b> .....4</p> <p><b>VI. System Voltage Adjustment</b>.....5</p> <p><b>VII. System Time Adjustment</b> .....5</p>	<p><b>VIII. Amp Manager</b>.....6</p> <p><b>IX. Equalization Voltage</b> .....6</p> <p><b>X. Equalization Time</b> .....7</p> <p><b>XI. Warning/Advisory Codes</b> .....7</p> <p><b>XII. Troubleshooting</b> .....8-9</p> <p>Sample Wiring Diagrams .....10-11</p> <p>Warranty .....12</p>
--	--

**Part # 90-2006-00**

## II. INSTALLATION (Continued)

4. (Continued). If the smaller battery shows signs of overcharging, the RED wire can be moved to the smaller battery terminal on the isolator. The same is true in the case of a dual-output alternator. The RED wire carries up to 6 amps and should be protected with the 10A fuse included with the regulator. Fusing should be as close to the power source as possible. If lengthening of the RED wire is needed, upgrade wire to 12-gauge.
5. Connect the two **BLACK** ground wires at the preferred ground at the rear of the alternator (see **Figure 2** for typical alternator ground connection).
6. Connect duplex plug with **BLUE** and **WHITE** wires to the alternator. If your alternator doesn't provide for a plug connection, see alternator manual for installation instructions.
7. If your application utilizes an electric tachometer, connect one end of the **WHITE** stator wire to the alternator and the other end to the regulator. A Tach Out terminal is provided for connection to your tachometer. If a new alternator is being installed, ensure that your tachometer is adjusted to meet your alternator's pole setting.
8. Attach optional Alternator Temp Sensor to the Alternator Temp Sensor terminals shown in **Figure 6**. Observe polarity. Attach sensor to alternator case as shown in **Figure 3**. Installing a toggle switch between the positive and negative terminals of the Alternator Temperature Sensor circuit allows you to reduce alternator output and horsepower load by 50% (Small Engine Mode).
9. Attach optional Battery Temp Sensor wires as shown in **Figure 6**. Observe polarity. Attach Battery Temp Sensor lug to negative battery terminal as shown in **Figure 4**. If used in a multi-battery bank, place as close to the middle of the bank as possible.
10. The **Alarm Output** (Dash Lamp) terminal provides a circuit for dash mounted visual or audible system warnings. Terminal output is 250 Mil-Amps (0.25A) negative when activated by low voltage (12.8V), high voltage (1V over bulk), high alternator temp (225F), or high battery temp (125F).

The **Aux. Out** terminal operates the same as the alarm output and activates at alt. full capacity, small engine mode, and during equalization.

### NOTE

Connection of the WHITE stator wire to the regulator is only recommended when an electric tach is used. Do not connect the WHITE wire to the regulator if your tachometer is being driven mechanically. Doing so may result in higher-than-recommended surface voltages at the batteries, as the regulator attempts to compensate for full battery capacity. If voltage climbs above normal levels, add a load (cabin lights, fan, etc.) to return the system to normal levels.

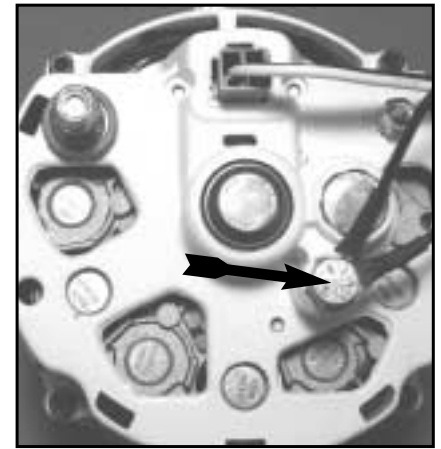

**Figure 2 - Ground attachment.** Both grounds connect together at preferred ground terminal.

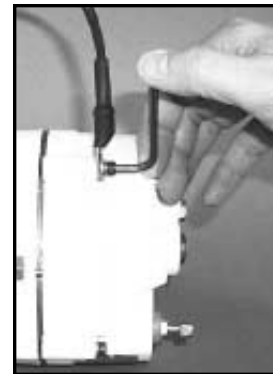

**Figure 3 - Optional Alternator Temperature Sensor.** Attach to mid-case mounting bolt.



**Figure 4 - Optional temp sensor on battery.** Connect to negative terminal.

Primary Program Settings	PRG-1 Universal Factory Program	PRG-2 Deep Cycle Flooded Lead Acid	PRG-3 Gel Cell	PRG-4 Absorbed Glass Mat (AGM)	PRG-5 Optima Spiral Wound
<b>Mode</b>					
<b>Start Delay (Seconds)</b>	45	45	45	45	45
<b>Ramp Up (Seconds)</b>	60	60	60	60	60
<b>Bulk Voltage (Max)</b>	14.1	14.6	14.1	14.4	14.6
<b>Bulk Time (Minimum)</b>	30 min.	30 min.	30 min.	30 min.	30 min.
<b>Absorption Voltage</b>	13.9	14.4	13.9	14.2	14.4
<b>Absorption Time (Minimum)</b>	0.2 hr.	0.2 hr.	0.2-2.0 hr.	0.2-2.0 hr.	0.2-2.0 hr.
<b>Float Voltage</b>	13.4	13.4	13.7	13.4	13.4
<b>Float Time (Maximum)</b>	6 hr.	6 hr.	6 hr.	6 hr.	6 hr..
<b>High Voltage Alarm</b>	15.2	15.6	15.1	15.4	15.6
<b>Low Voltage Alarm</b>	12.8	12.8	12.8	12.8	12.8
<b>Max Battery Temperature</b>	125F/52C	125F/52C	125F/52C	125F/52C	125F/52C
<b>Max Alternator Temperature</b>	225F/107C	225F/107C	225F/107C	225F/107C	225F/107C
<b>Equalization</b>	Yes	Yes	No	Consult Mfg.	Consult Mfg.

**Figure 5 - Preset program values.** Voltages may vary by +/- 3% from values shown.

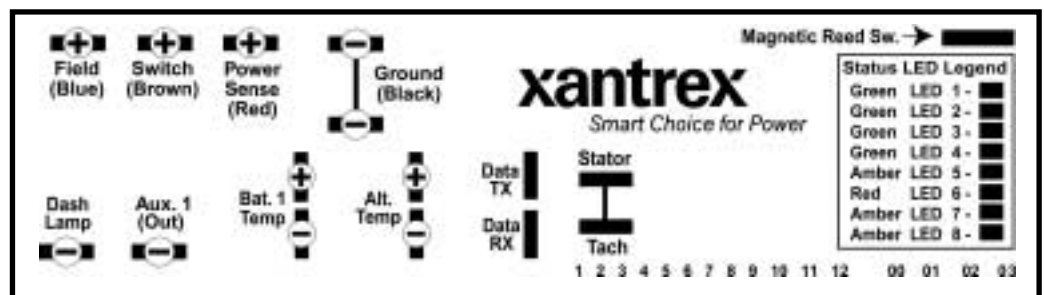

**Figure 6 - Regulator terminal layout and function description.** Locations may vary by regulator version. See label on side of regulator.

### III. OPERATION

Once the regulator is properly installed and connected to the rest of the charging system, it is ready to use. During operation, a bank of eight (8) color-coded LED lights will illuminate to provide programming, mode, diagnostic and advisory information. At start-up, **all eight LED lights** will illuminate for approximately three seconds (**Figure 7**). **Arrows indicate illuminated LEDs.**

**Figure 7 -**  
Indicates system start-up.



The initial display will be followed by a display which indicates battery program type (**Figure 8**). Out of the box, this will indicate the Universal Factory Program mode (indicated by a single green LED furthest from amber LED). Two green LEDs indicate Flooded Deep Cycle. Three green LEDs indicate Gel. Four green LEDs indicate Absorbed Glass Mat (AGM) battery. A single green LED closest to the illuminated amber LED indicates Optima battery setting.

**Figure 8 -** Indicates preset program. (Program #1 - Universal factory program shown.)

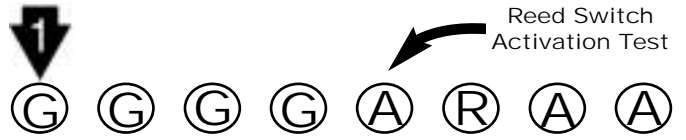

The display will then cycle through the various charging stages (**Figure 9**). Single green LED furthest from the amber LED indicates 45-second start delay. Two illuminated green LEDs indicate soft ramp and bulk charging stage. Three illuminated green LEDs indicate absorption stage. Four illuminated green LEDs indicate float stage.

**Figure 9 -** Indicates charging stage. (Start delay shown.)

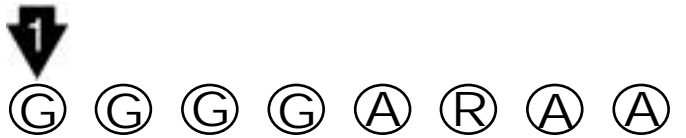

During normal operation, the regulator will delay alternator start-up for 45 seconds to allow belts to seat and engine lubrication to occur. After the initial start delay, the regulator will ramp to charging voltage over a one-minute period. Once bulk charging voltage is reached, the regulator will remain in the bulk stage for a minimum of 36 minutes. At the end of the 36-minute period, the regulator will compare actual battery voltage with target voltage (based on battery type) and determine whether to advance to absorption stage, or add additional 6-minute increments at bulk voltage until target voltage is reached.

Once in absorption stage, the regulator will remain at absorption voltage for a minimum of 36 minutes. Additional 6-minute increments will be added thereafter until target voltage is attained. Regulator will remain in float stage for a minimum of two hours, after which, it will cycle back to absorption stage for a minimum of 36-minutes. This cycle will continue throughout engine operation. **Note: The regulator will automatically return to the beginning of the charging program if the engine is shut down and re-started.**

### IV. PROGRAMMING FOR BATTERY TYPE

The XAR is factory preset for universal, “plug-and-play” operation with most battery types. In addition to the default factory program, both models feature selectable programs for Deep-Cycle flooded, AGM, Gel and Optima battery types. (A list of detailed voltage and time values for the various presets is available on the previous page. See **Figure 5**.) A magnetic reed switch, located beside the first green LED enables user adjustment. The switch works in two specific actions, as described in the box at right.

To select a program for your battery type:

1. Turn ignition key to its **ON** position. Allow the regulator to cycle through the 45-second start delay and into the ramp-up/bulk stage (indicated by the two illuminated green LEDs).
2. Using the supplied magnetic screwdriver (as shown in **Figure 11**), **ACTIVATE-HOLD** as discussed in the instructions at right. The #5 amber light and #6 flashing red light will illuminate to indicate switch activation (**Figure 10**).

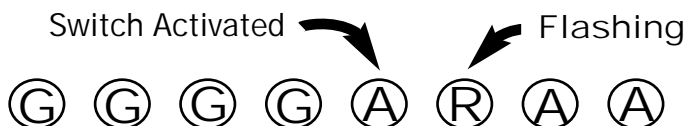

**Figure 10 -** Indicates magnetic switch is activated.



**Figure 11 -** Magnetic reed switch / LED location.

**‘ACTIVATE-RELEASE’** Refers to the activation and immediate deactivation of the switch by lowering the supplied magnetic screwdriver on the upper corner of the switch, and immediately deactivating the switch by removing the magnet from the switch.

**‘ACTIVATE-HOLD-RELEASE’** Used primarily during user programming, this action requires holding the magnet to the switch until desired values are shown on the display. Once the desired setting is reached, the magnet is removed to deactivate the switch.

**NOTE:** The cycle speed for the display is five seconds. The regulator cycles at this rate to ensure adequate time to read LED codes and make adjustments.

3. The red LED will stop flashing and the #7 amber light will illuminate shortly thereafter to indicate the battery preset program mode is engaged (**Figure 12**).

**Figure 12** - Indicates preset program mode.

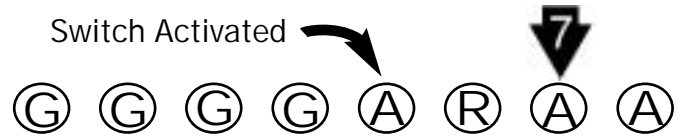

4. As you continue to hold, the green lights on the left half of the LED display will be illuminated one-by-one to indicate battery type. The first green LED on the left will indicate Program 1 (Universal Factory Program). As you continue to hold the magnet to the switch, the display will cycle to the first two green LEDs (indicating Program 2 - Deep Cycle), three green LEDs (indicating Program 3 - Gel), four green LEDs (indicating Program 4 - AGM), or a single green LED closest to amber LED (indicating Program 5 - Optima).

5. When the desired preset program is indicated, release the reed switch by removing your magnetic tool from the switch. Once a preset has been selected and the switch has been deactivated, the #5 amber light will go out, indicating that the switch has been deactivated. The green LED lights will remain for several second before going out (**Figure 13**).

**Figure 13** - Indicates program has been selected and switch has been released.

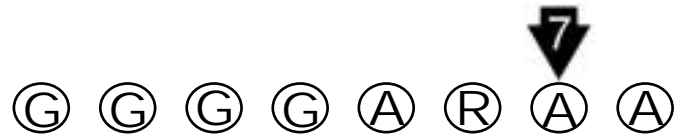

6. Once the green lights have gone out, you may change your selection by re-applying the magnet to the switch. The program choices will scroll in reverse order. **Note: Keep in mind that the display will stop scrolling once it reaches selection one or five (depending on if you are ascending or descending in the program mode).** It will be necessary to release the switch, wait for the green lights to go out, and re-apply the magnet to the switch to scroll in the opposite direction.

7. If the switch is not re-activated for several seconds, the #7 amber LED will flash (Figure 14) to indicate that the program changes have been saved and the display will return to the “basic” mode as described in **Section III**.

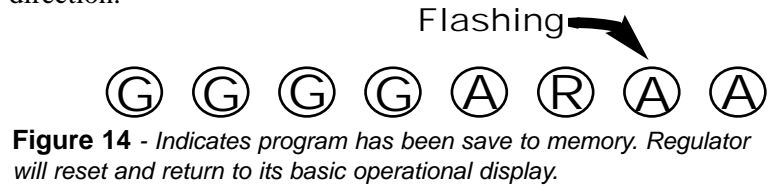

## V. ADVANCED PROGRAMMING

Advanced Programming modifies preset programming to suit specific charging needs. Advanced programming includes voltage adjustment, time adjustment, and equalization (time and voltage) adjustment. (**Equalization is only suggested for batteries noted as “equalization friendly” in Figure 5 on Page 2**). Consult your battery manufacturer for equalization time and voltage recommendations. Equalization must be initiated through the advanced programming mode. It is NOT a standard mode of operation. Both EQ time and voltage must be set for equalization to occur. Equalization will occur immediately after the program has been saved into memory. Once equalization is complete, the regulator will cycle to float mode. The XAR also features an adjustable Amp Manager, which enables you to control the percentage of total alternator output. This feature can be helpful in eliminating belt slippage which may occur if your drive belt is too small for the alternator load. **NOTE: Advanced Programming modifications can be removed from the regulator's memory by reselecting the original program for your battery type. NOTE #2: The Advanced Programming Mode will cycle three times before saving new settings to memory.** To enter to Advanced programming mode:

1. **ACTIVATE-HOLD** the magnetic reed switch. LED #5 will illuminate and LED #6 will flash several times (**Figure 15**).

**Figure 15** - Indicates entry to Advanced Programming mode.

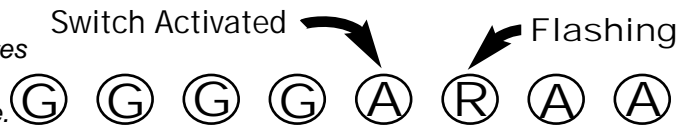

2. Continue holding switch. LED #6 stops flashing, then LED #7 illuminates. This indicates the regulator has entered the advanced program mode (**Figure 16**).

**Figure 16** - Indicates activation of Advanced Program mode.

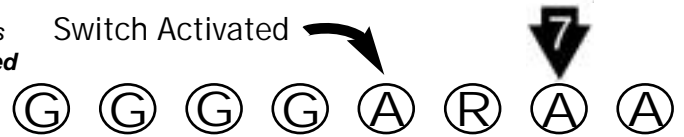

3. **RELEASE** the switch. The #5 amber LED will go out. The #7 amber LED will remain for several seconds and will be replaced by the #8 amber LED, indicating that the regulator is in the System Voltage Adjustment mode (**Figure 17**).

**Figure 17** - Indicates entry into the Advanced System Voltage Adjustment mode.

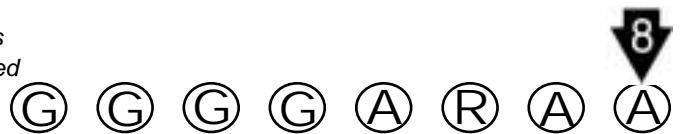

**The display will scroll three times through all of the Advanced Programming modes (System Voltage, System Time, Amp Manager, EQ Voltage, EQ Time). You may wait until the desired adjustment mode is reached before activating the switch.**

## VI. SYSTEM VOLTAGE ADJUSTMENT

The Voltage Adjustment mode allows you to increase or decrease the voltage values built into the preset programs based on battery type. **Note: Changes in charging voltages affect ALL stages of the charging program.** Keep in mind that the display has been programmed to provide approximately five seconds between value changes. This time period is provided to ensure correct adjustments. To adjust system voltage values:

1. When the LED indicates entry into the system voltage mode, as shown in **Figure 17**, **ACTIVATE-HOLD** the switch with your magnetic screwdriver (**Figure 18**). The display will begin to cycle up through the values shown in **Figure 19**. **NOTE: To reverse scrolling direction, release the switch, wait until the**

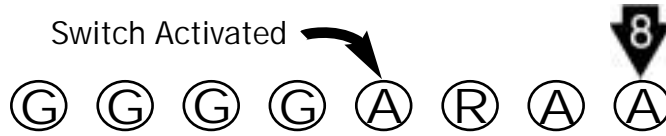

**Figure 18** - Indicates activation of **System Voltage Adjustment**. Green LEDs indicate as shown in **Figure 19**.

green lights turn off, and re-activate and hold the switch to cycle the opposite direction.

2. When the display indicates your desired voltage adjustment, **RELEASE** the switch.
3. After several seconds, the green indicator lights will turn off.
4. If no changes are made to your selection, the #8 amber light will flash once, indicating that your selection has been accepted. The display will advance to the **System Time Adjustment** mode.

## VII. SYSTEM TIME ADJUSTMENT

The System Time Adjustment enables you to modify charging time values to meet your battery bank's specific charging needs. Keep in mind, *changes in charging times affect ALL charging stages.* To modify charging time values:

1. When the LED display indicates entry into the system time adjustment mode, as shown in **Figure 20**, **ACTIVATE-HOLD** the switch with your magnet. The display will cycle up through the values shown in **Figure 22**. **NOTE: To reverse scrolling direction, release the switch, wait until the green lights turn off, and re-activate and hold the switch to cycle the opposite direction.** Keep in mind that the display has been programmed to provide approximately five seconds between value changes.
2. When the display indicates your desired system time adjustment, **RELEASE** the switch.
3. After several seconds, the green LEDs will turn off.
4. If no changes are made to your selection, the #7 and #8 (amber) lights will flash once, indicating that your selection has been accepted. The display will advance to the **Amp Manager** programming mode as illustrated in **Figure 23**.

LED Display	Voltage Indicated
↓ ↓ ↓ ↓ ↓ ↓ ↓ ↓ G G G G A R A A	System Voltage +0.8 volts
↓ ↓ ↓ ↓ ↓ ↓ ↓ ↓ G G G G A R A A	System Voltage +0.6 volts
↓ ↓ ↓ ↓ ↓ ↓ ↓ ↓ G G G G A R A A	System Voltage +0.4 volts
↓ ↓ ↓ ↓ ↓ ↓ ↓ ↓ G G G G A R A A	System Voltage +0.2 volts
↓ ↓ ↓ ↓ ↓ ↓ ↓ ↓ G G G G A R A A	<b>System Voltage</b>
↓ ↓ ↓ ↓ ↓ ↓ ↓ ↓ G G G G A R A A	System Voltage -0.2 volts
↓ ↓ ↓ ↓ ↓ ↓ ↓ ↓ G G G G A R A A	System Voltage -0.4 volts

**Figure 19** - Indicates entry into the Advanced System Voltage adjustment mode. Adjustment begins at System Voltage setting.

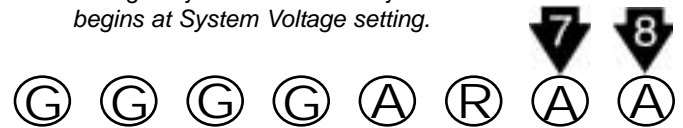

**Figure 20** - Indicates entry into Advanced System Time Adjustment.

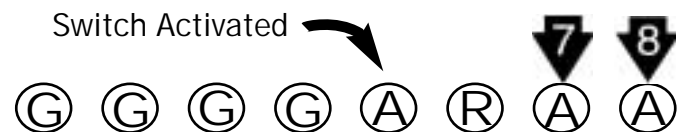

**Figure 21** - Indicates Advanced System Time Adjustment. Green LEDs indicate as shown in **Figure 22**.

LED Display	Time Indicated
↓ ↓ ↓ ↓ ↓ ↓ ↓ ↓ G G G G A R A A	Bulk +0.8hr. Absorb +0.8 hr Float +2 hr.
↓ ↓ ↓ ↓ ↓ ↓ ↓ ↓ G G G G A R A A	Bulk +0.6hr. Absorb +0.6 hr Float +1.5 hr.
↓ ↓ ↓ ↓ ↓ ↓ ↓ ↓ G G G G A R A A	Bulk +0.4hr. Absorb +0.4 hr Float +1 hr.
↓ ↓ ↓ ↓ ↓ ↓ ↓ ↓ G G G G A R A A	Bulk +0.2hr. Absorb +0.2 hr Float +0.5 hr.
↓ ↓ ↓ ↓ ↓ ↓ ↓ ↓ G G G G A R A A	<b>System Time</b>
↓ ↓ ↓ ↓ ↓ ↓ ↓ ↓ G G G G A R A A	Bulk -0.2hr. Absorb -0.2 hr Float -0.5 hr.
↓ ↓ ↓ ↓ ↓ ↓ ↓ ↓ G G G G A R A A	Bulk -0.4hr. Absorb -0.4 hr Float -1 hr.

**Figure 22** - Illustrates system time values as indicated by LED readout.

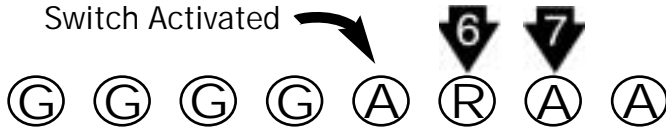

**Figure 23** - Indicates entry into Amp Manager Adjustment.

## VIII. AMP MANAGER

The Amp Manager function enables you to reduce the alternator's output by controlling the voltage at the field wire. This feature can be used as a method to minimize alternator overheating in warmer climates, or to minimize difficulties with belt slippage. To adjust Amp Manager values:

1. When the LED display indicates entry into the **Amp Manager** mode, as shown in **Figure 23** on the previous page, **ACTIVATE-HOLD** the switch with your magnetic tool. The display will indicate initial entry into Amp Manager program mode as illustrated in **Figure 24**, after which, the display will indicate



**Figure 24** - Indicates activation of **Amp Manager Adjustment**. Field output reduction percentages are shown in **Figure 25** at right.

100% output. Release and re-activate after the green light goes out to scroll downward through the program selections. Reversing the process will scroll upward.

2. When the display indicates your desired Amp Manager value as indicated in **Figure 25**, **RELEASE** the switch.
3. After several seconds, the green indicator lights will turn off.
4. If no changes are made to your selection, the #6 red and #7 amber lights will flash once, indicating that your selection has been accepted. The display will advance to the **Equalization Voltage Adjustment** mode as indicated in **Figure 26**.

## IX. EQUALIZATION VOLTAGE

The onset of sulfation can be lessened in some battery types by periodic introduction of elevated voltage to the battery. See **Figure 5** on Page 2 to determine if your battery type will benefit from equalization. Voltage values are based on system voltages determined by your preset program. Max. allowable voltage is 15.8 volts. **CAUTION: Consult with your battery manufacturer for recommended equalization time and voltage. Both time and voltage values must be set for equalization to occur.**

1. When the LED indicates entry into the EQ Voltage mode, as shown in **Figure 27**, **ACTIVATE-HOLD** the switch with your magnet (**Figure 28**). The display will show system voltage. When you activate the switch, the display will scroll up through the voltage values shown in **Figure 28**. Reversing the process will scroll downward.
2. When the display indicates your desired EQ voltage value, as indicated by the values shown in **Figure 28**, **RELEASE** the switch.
3. After several seconds, the green indicator lights will turn off.
4. If no changes are made to your selection, the #6 red and #7 amber lights will flash once, indicating that your selection has been accepted. The display will advance to the **Equalization Time Adjustment** mode as indicated in **Figure 29**.

LED Display	Percentage Indicated
↓ ↓ ↓ ↓ ↓ ↓ ↓ ↓ G G G G A R A A	Indicates: Amp Manager at 100%
↓ ↓ ↓ ↓ ↓ ↓ ↓ ↓ G G G G A R A A	Indicates: Amp Manager at 90%
↓ ↓ ↓ ↓ ↓ ↓ ↓ ↓ G G G G A R A A	Indicates: Amp Manager at 80%
↓ ↓ ↓ ↓ ↓ ↓ ↓ ↓ G G G G A R A A	Indicates: Amp Manager at 70%
↓ ↓ ↓ ↓ ↓ ↓ ↓ ↓ G G G G A R A A	Indicates: Amp Manager at 60%
↓ ↓ ↓ ↓ ↓ ↓ ↓ ↓ G G G G A R A A	Indicates: Amp Manager at 50%
↓ ↓ ↓ ↓ ↓ ↓ ↓ ↓ G G G G A R A A	Indicates: Amp Manager at 40%

**Figure 25** - Illustrates percentages of field voltage as controlled by the Amp Manager feature.

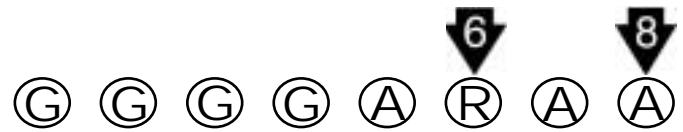

**Figure 26** - Indicates entry into **Equalization Voltage Adjustment**.

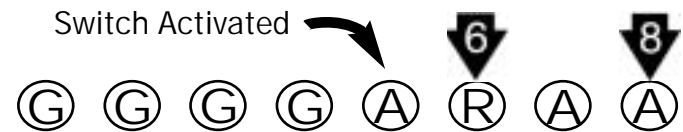

**Figure 27** - Indicates activation of **Equalization Voltage Adjustment**. Field output reduction percentages are shown in **Figure 28** at right.

LED Display	EQ Volts Indicated
↓ ↓ ↓ ↓ ↓ ↓ ↓ ↓ G G G G A R A A	Indicates: Sys. Volts +1.8V
↓ ↓ ↓ ↓ ↓ ↓ ↓ ↓ G G G G A R A A	Indicates: Sys. Volts +1.5V
↓ ↓ ↓ ↓ ↓ ↓ ↓ ↓ G G G G A R A A	Indicates: Sys. Volts +1.2V
↓ ↓ ↓ ↓ ↓ ↓ ↓ ↓ G G G G A R A A	Indicates: Sys. Volts +0.9V
↓ ↓ ↓ ↓ ↓ ↓ ↓ ↓ G G G G A R A A	Indicates: Sys. Volts +0.6V
↓ ↓ ↓ ↓ ↓ ↓ ↓ ↓ G G G G A R A A	Indicates: Sys. Volts +0.3V
↓ ↓ ↓ ↓ ↓ ↓ ↓ ↓ G G G G A R A A	<b>System Voltage</b>

**Figure 28** - Illustrates EQ Voltage settings. **Do not attempt equalization unless recommended by the battery manufacturer.**

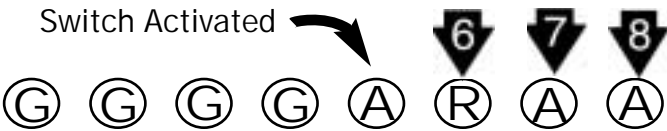

**Figure 29** - Indicates entry into **Equalization Time Adjustment**.



## X. EQUALIZATION TIME

The final mode in the Advanced Programming cycle is **Equalization Time Adjustment**. To change the duration of EQ time:

1. 

**Figure 30** - Indicates activation of **Equalization Time Adjustment**. EQ Time values are shown in **Figure 31** at right.

When the LED display indicates entry into the **Equalization Time Adjustment** mode, as shown in **Figure 29** on the previous page, **ACTIVATE-HOLD** the switch with your magnet. The display will show the system default time. Release the switch, wait for the green light to go out, and re-activate/hold switch. Equalization Time Adjustment values will scroll up as shown in **Figure 31**. Reversing the process will scroll downward.

2. When the display indicates your desired EQ time value, as indicated in **Figure 31**, **RELEASE** the switch.
3. After several seconds, the green indicator lights will turn off.
4. If no changes are made to your selection, the #6 red and #8 amber lights will flash once, indicating that your selection has been accepted. The Advanced Programming display will cycle two more times. If no other changes are made to your programming selections, the changes will be saved. A flashing #8 amber LED at the end of the final cycle indicates that your Advanced Programming selections have been saved.
5. Equalization will occur immediately after the EQ time and voltage values have been saved into memory, and will be indicated on the display by four green LEDs and a red LED. Once equalization is completed, the regulator will cycle to the float portion of the regular charge mode governed by your preset battery program.

*Advanced programming for System Voltage, System Time and Amp Manager functions will remain in the regulator's memory until they are modified within Advanced Programming, or until the Preset Program for battery type is re-selected.*

## XI. WARNING / ADVISORY CODES

The XAR is equipped to provide diagnostic information via the LED display. To access diagnostic data:

1. After the basic display mode (see **Section III**) has cycled through its initial start-up, **ACTIVATE-RELEASE** the magnetic switch with your magnetic tool.
2. The #6 red LED will begin to flash as the regulator scans through its diagnostic circuit.
3. When the regulator senses a situation requiring attention, the flashing #6 red LED will alternate with specific groupings of green LED lights.
4. Each LED grouping will correspond to a condition described in **Figure 33**. Each code will be displayed for several seconds, at which point, the regulator will continue to search for additional conditions. Error code searching will be indicated by the flashing #6 red LED.
5. After all warning/advisory codes are displayed, the regulator will return to basic display mode.

LED Display	Time Indicated
↓ ↓ ↓ ↓ ↓ ↓ ↓ ↓ G G G G A R A A	Indicates: +4.2 EQ hours
↓ ↓ ↓ ↓ ↓ ↓ ↓ ↓ G G G G A R A A	Indicates: +3.5 EQ hours
↓ ↓ ↓ ↓ ↓ ↓ ↓ ↓ G G G G A R A A	Indicates: +2.8 EQ hours
↓ ↓ ↓ ↓ ↓ ↓ ↓ ↓ G G G G A R A A	Indicates: +2.1 EQ hours
↓ ↓ ↓ ↓ ↓ ↓ ↓ ↓ G G G G A R A A	Indicates: +1.4 EQ hours
↓ ↓ ↓ ↓ ↓ ↓ ↓ ↓ G G G G A R A A	Indicates: +0.7 EQ hours
↓ ↓ ↓ ↓ ↓ ↓ ↓ ↓ G G G G A R A A	Indicates: Zero EQ hours

**Figure 31** - Illustrates EQ Time settings. **CAUTION:** Contact your battery manufacturer for recommended EQ time and voltage values. Do not attempt equalization unless recommended by the battery manufacturer.

Flashing Red



**Figure 32** - Indicates activation of diagnostic mode. Diagnostic codes are shown in **Figure 33** at right.

LED Display	Code Description
↓ ↓ ↓ ↓ ↓ ↓ ↓ ↓ G G G G A R A A	Indicates: Alt. over temp
↓ ↓ ↓ ↓ ↓ ↓ ↓ ↓ G G G G A R A A	Indicates: Battery temp shorted
↓ ↓ ↓ ↓ ↓ ↓ ↓ ↓ G G G G A R A A	Indicates: Battery temp not found
↓ ↓ ↓ ↓ ↓ ↓ ↓ ↓ G G G G A R A A	Indicates: Battery over temp
↓ ↓ ↓ ↓ ↓ ↓ ↓ ↓ G G G G A R A A	Indicates: Alt. temp not found
↓ ↓ ↓ ↓ ↓ ↓ ↓ ↓ G G G G A R A A	Indicates: Alt. temp shorted
↓ ↓ ↓ ↓ ↓ ↓ ↓ ↓ G G G G A R A A	Amp Manager/Small Engine Mode

**Figure 33** - Illustrates system diagnostic codes.

## Alternator and Regulator Troubleshooting

Determining the causes of failures in an electrical system is a “step by step” process. We recommend that you inspect and clean all system electrical connections before you begin your search to determine if the failure can be attributed to one of the two main components of your charging system: the alternator, and/or the voltage regulator.

**Most charging system problems will be corrected by performing the following steps.**

1. Remove and clean all charging system electrical connections from the alternator through the batteries (this includes the ground side). Also, check the voltage regulator’s harness for resistance. Wires and terminals can and will become corroded and need to be cleaned or replaced.
2. Charge all batteries to their proper fully charged state and determine if they are serviceable. If your batteries are flooded-type, use your hydrometer to determine their condition.
3. Check and tighten alternator belt. If the belt shows signs of wear or damage, now is an ideal time for replacement. Always replace existing belts with the finest quality replacements available.

After determining that your batteries and wiring are in suitable condition, use the following tests to determine if charging problems are a result of a faulty alternator or regulator. The following tests provide an opportunity to isolate the alternator, regulator and wiring harness in order to determine which component may be malfunctioning. In order to perform these tests, you will need an independent multimeter (preferably a digital type). In an emergency, a 12V light bulb can be used to help determine if power or working grounds exist. An amp meter and a battery hydrometer with a thermometer are also helpful diagnostic tools.

### **Alternator /Regulator Field Tests**

**Test A** - The alternator and regulator can be tested for function by determining if a magnetic field exists at the alternator’s pulley shaft or rear bearing. To test:

1. With the ignition in the OFF position, place the head of a steel screwdriver near the nut on the pulley shaft or near the rear bearing of the alternator. There should be no evidence of a magnetic field pulling the screwdriver toward the alternator.
2. Engage the ignition, without starting the engine, to activate the voltage regulator. If an oil pressure switch is used, a jumper across the switch will activate the regulator.
3. After allowing time for the regulator’s start-up delay, place the head of a steel screwdriver near the nut on the pulley shaft or near the rear bearing of the alternator. There should be evidence of a magnetic field pulling the screwdriver toward the alternator. If a magnetic field is present, the voltage regulator, alternator brushes and rotor are likely to be working properly. If the system is not charging, remove the alternator and have it inspected by a qualified alternator shop.

**Test B** - If there is little or no magnetic pull at the pulley shaft or at the rear bearing, initiate the following test:

1. With the key off and the engine off, remove the large harness plug from the regulator.
2. Insert the end of a short length of electrical wire to the RED connector slot of the regulator harness and the other end of the wire to the BLUE connector slot. (See **Figure 32.**) This bypasses the regulator and tests the alternator and the harness.
3. Using your steel screwdriver, inspect for a magnetic field as described above.
4. With your voltmeter, check for voltage on the blue wire at the alternator. If voltage does not exist, the harness may be at fault. If voltage does exist at the harness, but charging is not occurring, the alternator is likely to be malfunctioning.

If a magnetic field is present. Both harness and alternator brushes and rotor appear to be working properly. If no magnetic field is present, proceed with the next test.

**Test C** - Testing the actual output of the alternator is known as “Full Field Testing”. This can be accomplished by jumping a positive 12VDC current to the field terminal at the rear of the alternator. This test eliminates both the regulator and the harness, making it easier to isolate your investigation to the alternator.

**CAUTION: Ensure that all voltage sensitive equipment is turned off prior to starting the engine. Voltage is unregulated during this test and could damage sensitive electronics. DO NOT let the engine run any longer than necessary to detect charging.**



**Figure 32** - Full field jump wire.



To test the alternator:

1. Clip a jumper wire to the positive post of the alternator, or on the battery side of the isolator, if an isolator is in use (see **Figure 33**). Use a SHIELDED alligator clip for post attachment. Unintentional contact between the alligator clip and the alternator case could result in damage to your electrical system.
2. Disconnect the field/stator plug from the rear of the alternator and attach the other end of the jumper wire to the alternator's Field terminal (F). Attach a female spade connector to the field end of the wire for a solid connection. **CAUTION:** Do not allow the wire to contact the case while it is attached to the positive post. The case is grounded and severe damage could occur.
3. The regulator is now bypassed. When the ignition is engaged and the motor is started, the voltage should rise and charging current should be present.
4. The motor should be run long enough to determine that charging voltage is present. Unregulated voltage can rise quickly. Do not allow extended unregulated charging to occur without carefully monitoring voltage levels.

If the alternator fails to generate voltage during field testing, a malfunction of the alternator is likely. Contact your local alternator repair shop or Xantrex's technical service staff for recommendations.

### Voltage Regulator Test

When you have inspected and repaired any wires and connections, inspected belts and replace as needed, and after you have determined that your batteries are properly charged, set your voltmeter to 12V and connect the voltmeter's negative lead to the BLACK ground wire at the regulator. Normally, connection is accomplished by inserting the negative lead alongside the ground wire in the regulator harness plug and the positive lead alongside the wire referred to in each specific test (see **Figure 33**). With the voltmeter securely connected to the regulator's ground, test for voltage at the points listed below.

1. With the ignition in the OFF position and your voltmeter's ground wire connected to the regulator's ground, check for voltage on the RED (sensing), BLUE (field) and BROWN (ignition) wires in the regulator plug by inserting the positive lead of the voltmeter alongside each wire in the regulator harness plug. The voltmeter should read:

	Red Wire	Brown Wire	Blue Wire
<b>Expected Reading</b>	12 V *	0 V	0 V
<b>Your Reading</b>			

2. With the ignition in the ON position (engine not running) and your voltmeter's ground wire connected to the regulator's ground, check for voltage on the RED (sensing), BLUE (field) and BROWN (ignition) wires in the regulator plug. The voltmeter should read:

	Red Wire	Brown Wire	Blue Wire
<b>Expected Reading</b>	12 V*	12 V	7 - 12 V
<b>Your Reading</b>			

3. With the ignition in the ON position (with engine running at 1,400 rpm fast idle) and your voltmeter's ground wire connected to the regulator's BLACK wire, check for voltage on the RED (sensing), BLUE (field) and BROWN (ignition) wires in the regulator plug. The voltmeter should read:

	Red Wire	Brown Wire	Blue Wire
<b>Expected Reading</b>	12 - 14V**	12 V	4 - 12 V
<b>Your Reading</b>			

\* 11.5 - 12.8 VDC battery voltage at rest (no charging occurring). If your batteries are isolated and your RED (sensing) wire shows voltages other than those shown above, make sure that the wire is connected on the "battery" side of the isolator. The RED wire must "see" the battery directly.

\*\* 13.5 - 14.5 VDC battery voltage when charging.

If your readings differ substantially from the "Expected Readings" listed in the charts above, the regulator may be malfunctioning, or there may be a continuity problem. Contact our technical support staff. If you determine that repair service is necessary for either your alternator or regulator, please gather the following information before contacting our service technicians.

1. Model of alternator.
2. Model of voltage regulator.
3. Voltage readings on red, brown and blue wire at regulator with engine off, key on.
4. Voltage readings on red, brown and blue wire at regulator with engine running at a fast ideal 1400 rpm.

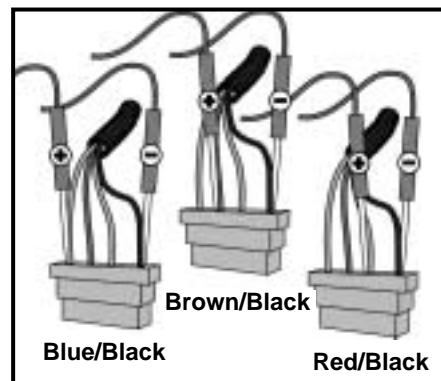
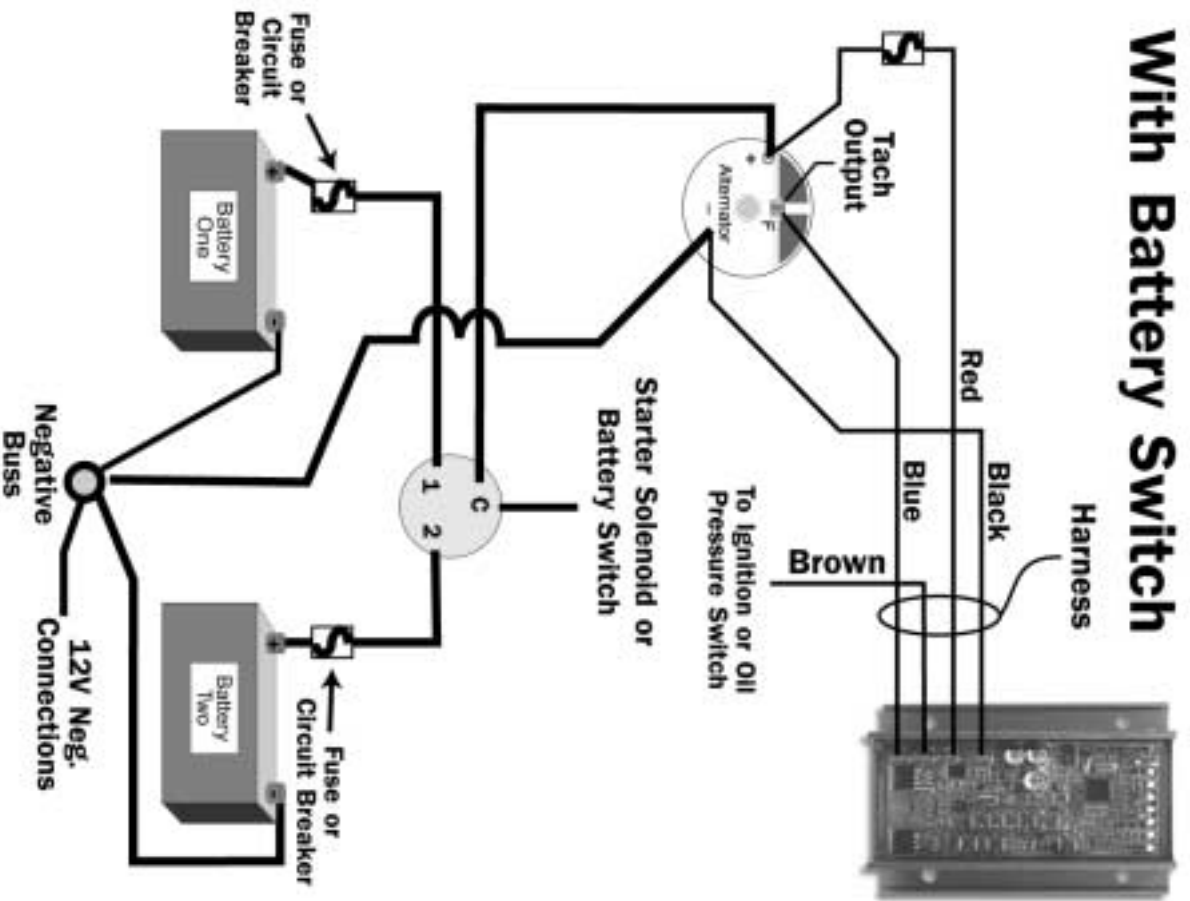

Figure 33 - Regulator voltage test.

# TYPICAL SYSTEM WIRING -

## Single Output Alternator

### With Battery Switch



### With Isolator

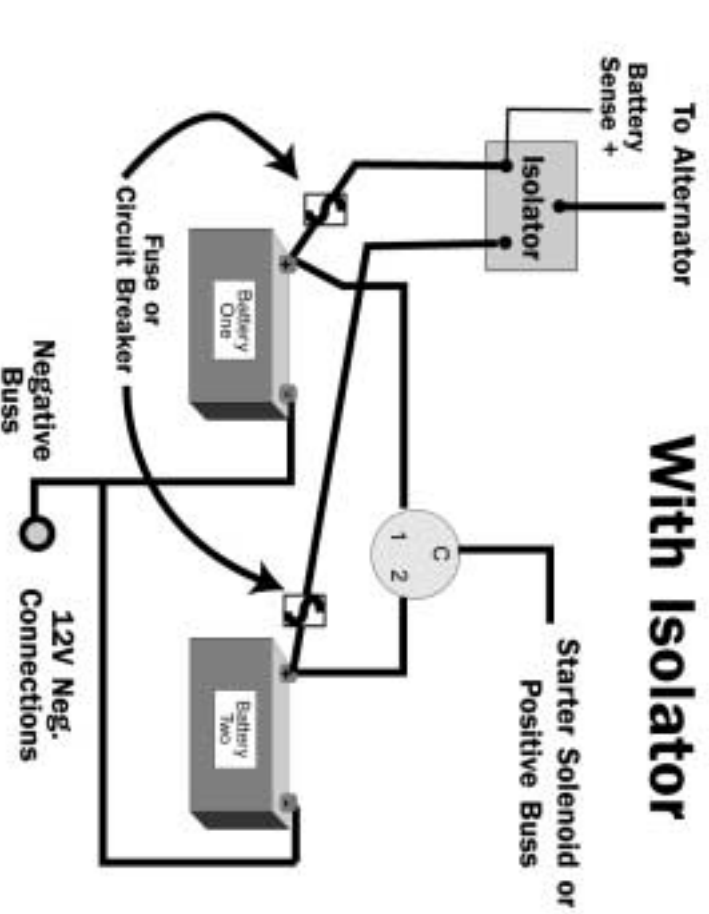

# TYPICAL SYSTEM WIRING - Dual Output Alternator

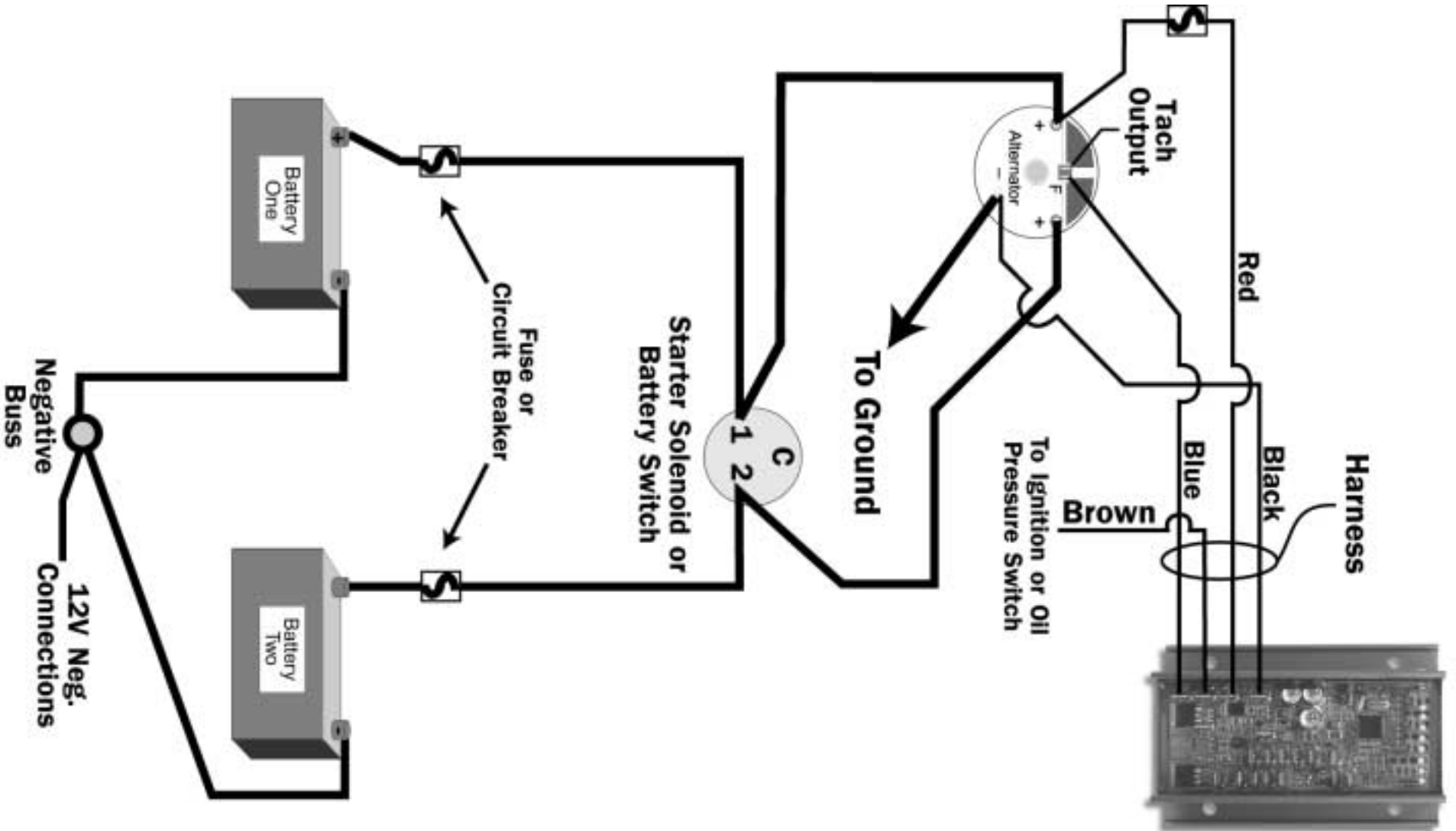

# Warranty

---

**What does this warranty cover?** Xantrex manufactures its products from parts and components that are new or equivalent to new, in accordance with industry standard practices. This warranty covers any defects in workmanship or materials.

**How long does the coverage last?** This warranty lasts for twelve months from date of purchase. Implied warranties or merchantability and fitness for a particular purpose are limited to twelve months from the date of purchase. Some jurisdictions do not allow limitations on how long an implied warranty lasts, so the above limitation may not apply to you.

**What does this warranty not cover?** This warranty will not apply where improperly installed, physically damaged or altered, either internally or externally, or damaged from improper use or use in an unsuitable environment. Xantrex does not warrant uninterrupted operation of its products. Xantrex shall not be liable for damages, whether direct, incidental, special, or consequential, or economic loss even though caused by the negligence or fault of Xantrex. Some jurisdictions do not allow the exclusion or limitation of incidental or consequential damages, so the above limitation or exclusion may not apply to you.

**What will Xantrex do?** Xantrex will, at its option, repair or replace the defective product free of charge. Xantrex will, at its own option, use new and/or reconditioned parts made by various manufacturers in performing warranty repair and building replacement products. If Xantrex repairs or replaces a product, its warranty term is not extended. Xantrex owns all parts removed from repaired products.

**How do you get service?** To qualify for the warranty, dated proof of purchase must be provided and the product must not be disassembled or modified without prior authorization by Xantrex. If your product requires warranty service, please return it to the place of purchase along with a copy of your dated proof or purchase. If you are unable to contact your merchant, or if the merchant is unable to provide service, contact Xantrex directly at:

Phone: 1-800-446-6180  
Fax: 1-360-925-5143  
E-Mail: techhelp@xantrex.com

## Return Material Authorization Policy

You must obtain a Return Material Authorization (RMA) number from Xantrex before returning product directly to Xantrex. Products returned without an RMA number or shipped collect will be refused. When you contact Xantrex to obtain service, be prepared to supply:

- The model number of your product
- The date of purchase
- Information about the installation and use of the product

## Return Material Procedure

If you are returning a product from the USA or Canada, follow this procedure:

1. Contact Xantrex to obtain an RMA number and a shipping address.
2. Package the unit safely, preferably using the original box and packing materials. Include the following:
  - The RMA number supplied by Xantrex
  - A copy of your dated proof of purchase
  - A return address where the repaired unit can be shipped
  - A contact telephone number
3. Ship the unit freight prepaid to the address provided in Step 1. Collect shipments will be refused.

**How do other laws apply?** This warranty gives you specific legal rights, and you may also have other rights which vary from jurisdiction to jurisdiction.

**For our Canadian customers:** When used herein "implied warranties of merchantability and fitness for a particular purpose" includes all warranties and conditions, express or implied, statutory or otherwise, including without limitation implied warranties and conditions of merchantability and fitness for a particular purpose.

## Product Information

---

Model number

---

Place of purchase

---

Date of purchase

---