CONTENTS

■ <i>A FEW WORDS ABOUT YOUR NEW AIR CONDITIONING UNIT</i>	2
■ <i>ELECTRICAL DATA</i>	2
■ <i>OPERATING INSTRUCTIONS</i>	3
■ <i>ENJOYING THE "AIR SHOWER"</i>	5
■ <i>ENERGY SAVING TIPS</i>	5
■ <i>INSTALLATION INSTRUCTIONS</i>	6
Step 1. Selecting an Installation Location & Installing the Roof Top Air Conditioner	6
Step 2. Installing the Ceiling Assembly	9
Step 3. Electrical Wiring	10
Step 4. Completing the Installation	11
■ <i>TROUBLE SHOOTING GUIDE</i>	12
■ <i>NORMAL MAINTENANCE PROCEDURES</i>	13
■ <i>PART DIAGRAM</i>	14

A FEW WORDS ABOUT YOUR NEW AIR CONDITIONING UNIT

Thank you for choosing the Air V, Carrier Recreational Vehicle Air Conditioner, for your cooling needs. You can feel confident in your selection because the same pride in craftsmanship and engineering knowledge that goes into Carrier equipment to cool the Astrodome in Texas, the famous Sistine Chapel in Rome, the Washington DC Halls of Congress and thousands of other installations worldwide has gone into the construction of your unit.

In addition to cooling the room, your Carrier unit will also filter and dehumidify the room's air. The Air V air conditioners quietly give you maximum cooling comfort. Now you can "Feel Carrier's Cool"!

This manual will supply you with all the information you need for installing, operating and maintaining your new unit. Take a few minutes to discover how to get the most in cooling comfort and economic operation from your new Air V.

Please keep this manual handy for future reference, and be sure to send in your warranty card. You can also contact us by the internet web site, www.airv.com.

ELECTRICAL DATA

- 1** All wiring must comply with local and national electrical codes. All wiring must be installed by qualified electricians. If you have any questions about the following instructions, contact a qualified electrician.
- 2** Check the available power supply and resolve any wiring problems BEFORE installing and operating this unit.
- 3** This air conditioner is designed to operate from a 115V AC, 60Hz, 1 Phase power supply.
- 4** The unit nameplate is located on the left side of the condenser orifice that is on the rear of the basepan. The wiring diagrams are located on the cover of the control box. The ceiling assembly unit wire diagrams are located on the ceiling panel.
- 5** Note the unit's model, serial number, and the ceiling assembly serial number. Record this information on the front cover of this manual. Refer to Figure 4 of page 9 for serial number location.

SCHEMATIC DIAGRAM of Upper Unit

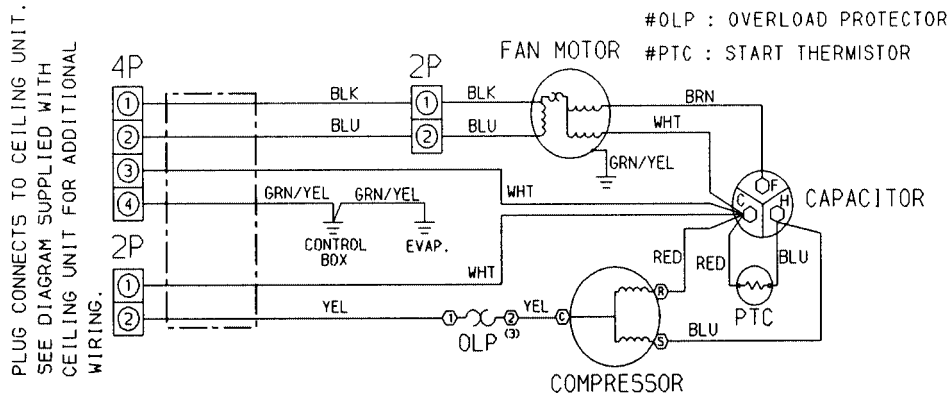

SCHEMATIC DIAGRAM of Ceiling Unit

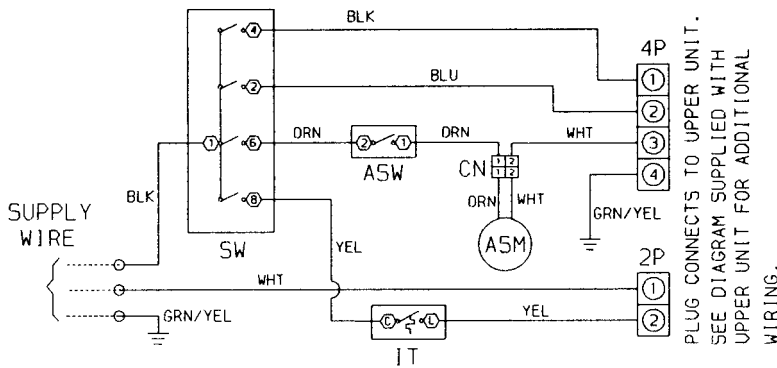

SWITCH POSITION	CONTACTS MADE
HIGH FAN	1-4 . 1-6
LOW FAN	1-2 . 1-6
OFF	NONE
LOW COOL	1-2 . 1-6 . 1-8
HIGH COOL	1-4 . 1-6 . 1-8

ASW	0 (OFF)	2
	1 (ON)	2 - 1

LEGEND
 ASM AIR SWEEP MOTOR
 ASW AIR SWEEP SWITCH
 SW SWITCH
 IT INDOOR THERMOSTAT
 CN HOUSING CONNECTOR

OPERATING INSTRUCTIONS

GLOSSARY OF CONTROL SYMBOLS

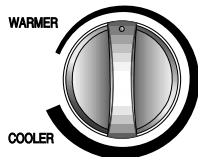

← Automatic Thermostat Control



← Air Sweep Control

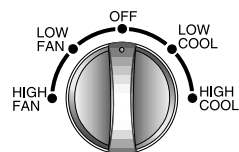

← Master Control

OFF

When dial is turned to the OFF position the unit will NOT operate. When leaving your vehicle for any period of time, make sure the master control dial is set to the OFF position.

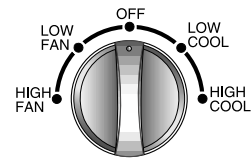

LOW FAN

LOW FAN will circulate relatively small quantities of air WITHOUT cooling. Choose the LOW FAN setting simply by rotating the dial to this position.

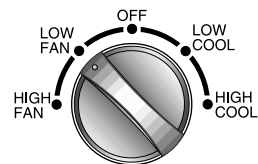

HIGH FAN

HIGH FAN will circulate larger quantities of air WITHOUT cooling. Choose the HIGH FAN setting simply by rotating the dial to this position.

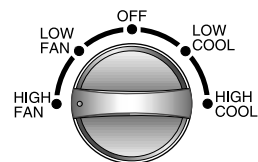

LOW COOL

LOW COOL will provide light cooling. Choose the LOW COOL setting simply by rotating the dial to this position. It is also recommended for nighttime use or relatively hot days.

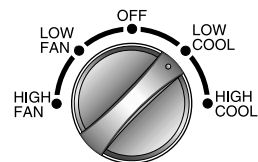

HIGH COOL

HIGH COOL provides maximum cooling. Choose the HIGH COOL setting simply by rotating the dial to this position. It is recommended for quick cooling or extremely hot days. Once the room is cooled, switch to a lower setting.

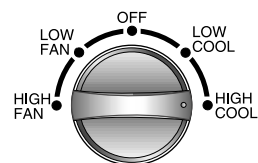

THERMOSTAT CONTROL

The thermostat maintains the room temperature automatically. Turn the thermostat toward COOLER for lower temperature control, or toward WARMER if a higher temperature setting is desired. The cooling operation automatically starts when the room temperature rises above your desired thermostat setting and stops when the room temperature reaches your desired setting. (NOTE: The fan will operate continuously to maintain optimum temperature control.)

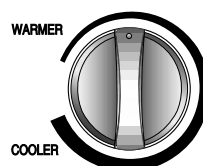

AIR SWEEP CONTROL

Your unit provides an automatic air sweep to cool the room more efficiently. When the air sweep switch is set on (I), the horizontal blade moves slowly up and down and distributes the air around the room. The direction of the vertical blades can be adjusted manually (make sure the air sweep is off). With the air sweep in the off position, the horizontal blade can be closed by pushing the PUSH mark on the blade, and can be opened by pushing it again.

I - Setting for automatic air sweep on

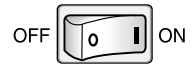

0 - Setting for automatic air sweep off

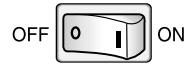

ENJOYING THE "AIR SHOWER"

1 Your unit provides you with more efficient cooling air with the direct air discharger. On extremely hot days or after much activity, you can take an "air shower" and cool off quickly.

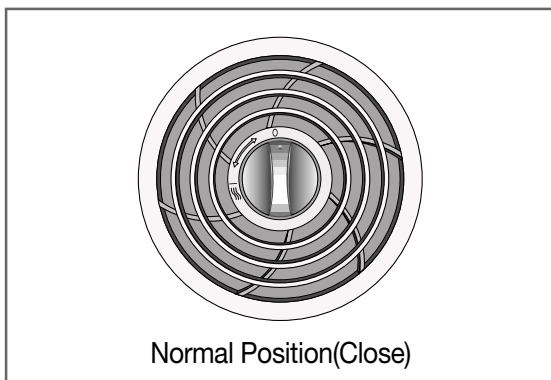

2 You can enjoy direct air by rotating the knob to the open position and closing the front or rear horizontal blade. (Closing the front blade may provide direct air more efficiently)



ENERGY SAVING TIPS

1 Select the thermostat setting that suits your comfort needs and leave it at that chosen setting.

2 Keep the unit's air filters clean. (See the Normal Maintenance Procedures section of this manual on page 13)

- 3** During extreme outdoor temperatures, the heat gain of the vehicle may be reduced by:
- parking the vehicle in a shaded area
 - keeping the windows and doors closed
 - avoiding the use of heat producing appliances
- using window shades (blinds and/or curtains)
- For a more permanent solution to reduce the high heat gain, window awnings and/or window glass tinting should be considered.

INSTALLATION INSTRUCTIONS

BEFORE INSTALLATION

Test run the unit with proper power supply outlet. Refer to the Operating Instructions section in this Owner's Guide. Make sure all the controls operate correctly then disconnect the power supply of the unit.

WARNING

Moving parts can cause personal injury. Be careful when test-running the unit. Do not operate the unit with exterior cover removed.

STEP 1 - SELECTING AN INSTALLATION LOCATION & INSTALLING THE ROOF TOP AIR CONDITIONER

Your Air V unit has been designed for use in recreational vehicles.

Check the roof of the vehicle to determine if it supports both the roof top unit and the ceiling assembly without additional support. Make sure the interior ceiling mounting area will not interfere with existing structures.

Once the location for your air conditioner has been determined, a reinforced and framed roof hole opening must be cut (if there is no hole) or you may use existing vent holes.

CASE A.

If a roof vent is already present in the desired mounting location for the air conditioner, the following steps must be performed:

- 1** Remove all screws which secure the roof vent to the vehicle. Remove the vent and any additional trim. Carefully remove all chalking from around the opening so the surface is clear.
- 2** It may be necessary to seal some of the old roof vent mounting screw holes which may fall outside of the air conditioner basepan gasket.
- 3** Examine the roof opening size. If the opening is smaller than 14" x 14", the opening must be enlarged. If the opening exceeds 14" x 14", a mounting plate (frame) must be fabricated to reduce the opening size (See Figure 1).

CASE B.

If a roof vent opening is not used, a new opening (See Figure 1) will have to be cut into the vehicle roof. A matching opening will also have to be cut into the interior vehicle ceiling. Be careful when cutting the ceiling opening because if the ceiling opening is carpeted, snagging could occur. After the opening in the roof and interior ceiling are the correct size, a framed support structure must be placed between the exterior roof top and interior ceiling. The reinforced framed structure must follow the following guidelines:

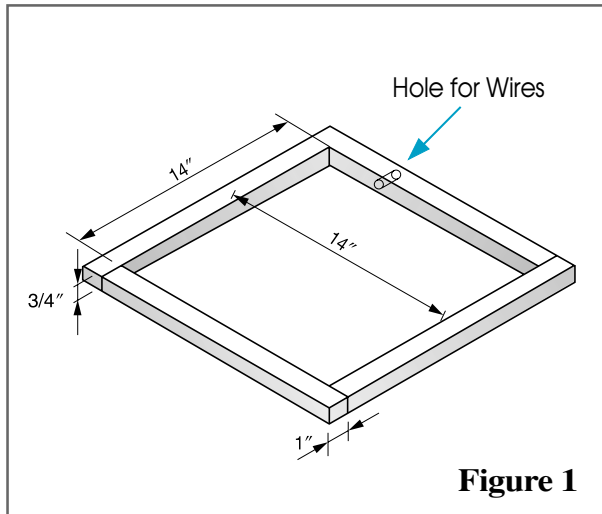

Figure 1

1 It must be capable of supporting both the weight of the roof top air conditioner and the interior ceiling assembly

2 It must be capable of holding the roof outer surface and interior ceiling apart and supporting them, so that when the roof top air conditioner and ceiling assembly are bolted together, no collapsing occurs.

We recommend that the spacing between the vehicle roof top and the interior ceiling top be no less than 3/4". A typical support frame is shown in Figure 1.

3 There must be an opening through the frame for the power supply wiring. Route the supply wiring through the frame at the same time the support frame is being installed.

CAUTION

- Allow 24" (working length) of supply wiring through the support frame and make sure that all wiring passing through any mechanical structure must be protected from insulation chaffing using a rubber grommet or strain relief.
- After the support frame is built and both the roof exterior and the interior ceiling are cut, make sure that the electrical wiring can be routed to the control board. Seal the gap around the electrical supply wiring using a rubber grommet.

CAUTION

- The roof top air conditioner must be mounted on a level plane from front to rear and side to side when the vehicle is parked on a level plane. Figure 2 shows maximum allowable degrees that the Air V can be mounted above or below level.

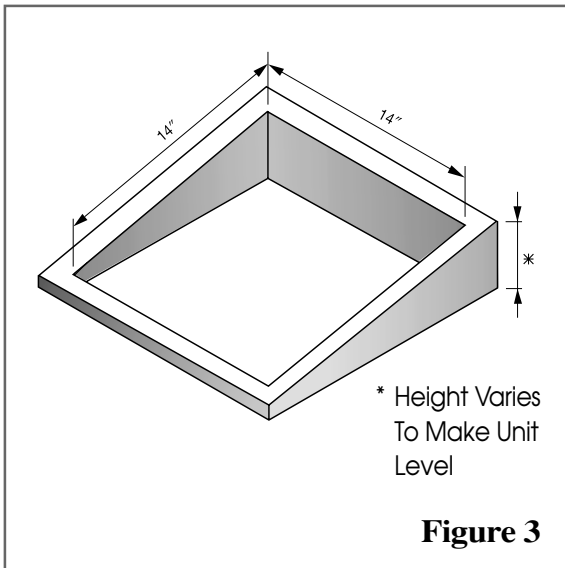
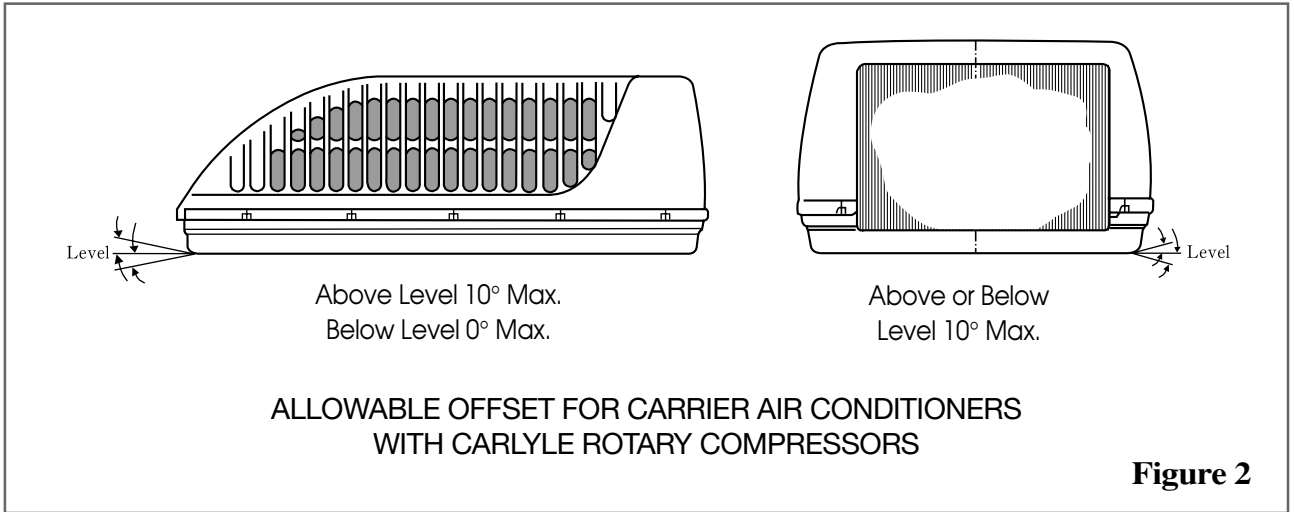

- If the roof of the vehicle is sloped (not level) such that the roof top air conditioner cannot be mounted within the maximum allowable degree specifications, an exterior leveling shim will need to be added to make the Air V level. A typical leveling shim is shown in Figure 3.
- Once the roof top air conditioner has been leveled, some additional shimming may be required above the interior ceiling assembly. The roof top air conditioner and the interior ceiling assembly must be square with each other before they are secured together.
- After the mounting hole area is properly prepared, remove the carton and shipping pads from around the roof top air conditioner. Carefully lift the unit on top of the vehicle. Do not use the outer plastic shroud for lifting. Place the roof top air conditioner over the prepared mounting hole.
- The pointed end (nose) of the shroud must face toward the front of the vehicle. From inside the vehicle, pull the electrical harness down from the roof air conditioner through the mounting opening and let it hang.

NOTE

AIR CONDITIONER DIMENSIONS (Roof Top Unit)

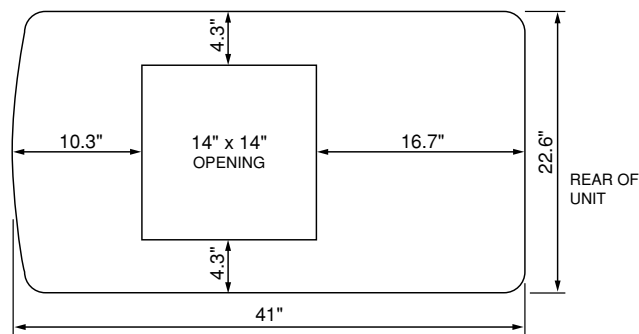

STEP 2 - INSTALLING THE CEILING ASSEMBLY

Make sure that you have properly matched the roof top air conditioner and interior ceiling assembly. The following step by step instructions must be performed in the following sequence to insure proper installation.

- 1** Carefully take the ceiling assembly out of the carton. (The controls are factory installed in the ceiling assembly.)
- 2** Remove the ceiling grille from the ceiling assembly frame.
- 3** Before the ceiling assembly can be mounted to the roof top air conditioner, the fabric duct collar must be fastened to the basepan of the air conditioner with 4 screws (See ①, Figure 4).
- 4** Before lifting (mounting) the ceiling assembly, check the gasket on the underside of the roof top air conditioner. The gasket must be centered over the roof opening.
- 5** Before lifting the ceiling assembly, pull the fabric duct collar so it hangs out of the way and does not get caught under the ceiling assembly frame.
- 6** Secure the ceiling assembly frame to the roof top air conditioner with the mounting bolts (See ②, Figure 4). You must start (thread) the mounting bolts by hand to avoid cross-threading. **DO NOT START THE MOUNTING BOLTS WITH AN AIR GUN.** The mounting bolts should be tightened evenly. Do not over-tighten each bolt. The bolt tightening process is complete when the basepan gasket has been evenly compressed to 60%.
- 7** Pull the fabric duct collar through the ceiling assembly frame opening and pull the four corners to extend below the duct opening (See ③, Figure 4).

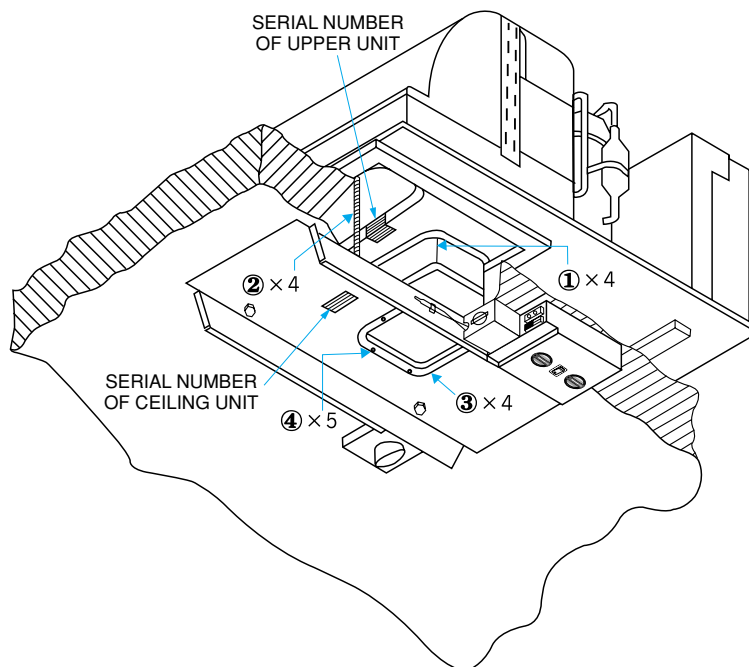

Figure 4

⚠ WARNING

DO NOT USE DUCT TAPE ON OR AROUND FABRIC DUCT COLLAR.

- 8 Pull fabric tight. This will prevent the material from gathering inside the discharge duct.
- 9 Fasten each side of the fabric duct with fitting the duct plate to the ceiling assembly plate with 5 screws (See 4, Figure 4). Trim any excess fabric that may extend beyond edge of duct plate.

STEP 3 - ELECTRICAL WIRING

ROUTING 115V AC WIRING

⚠ WARNING

MAKE SURE THAT ALL POWER SUPPLY TO THE UNIT IS DISCONNECTED BEFORE PERFORMING ANY WORK ON THE UNIT TO AVOID THE POSSIBILITY OF SHOCK OR INJURY AND/OR DAMAGE TO THE EQUIPMENT.

After the interior ceiling assembly frame is properly secured to the roof top air conditioner, the following electrical connections must be performed.

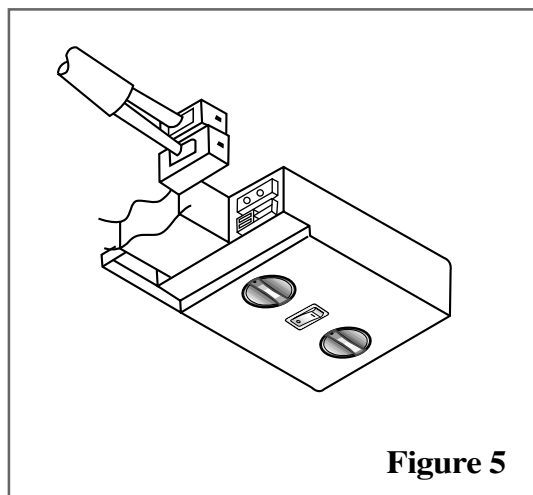
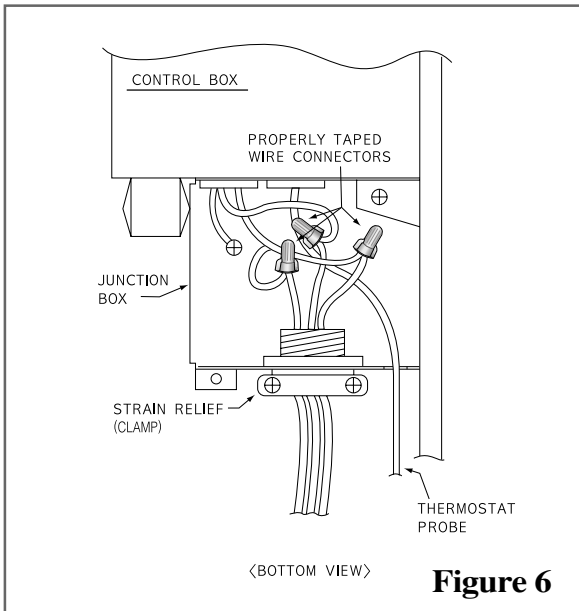

Figure 5

- 1 Route a copper, with ground, supply wiring with minimum, #12 AWG from its power source to the junction box. Do not attach them at this time.
- 2 Take the roof top air conditioner electrical harness and plug it into the side of the selector switch control box. Make sure that the "ridged" side of the plug is aligned and matched with the "ridged" side of the selector switch control box connection. DO NOT USE EXCESSIVE FORCE (See Figure 5).
- 3 Remove the junction box cover (1 screw). Take the supply wire and slide it into the back of the junction box through the strain relief that is provided.

CAUTION

WHEN USING INSULATED CABLES, STRIP THE OUTER JACKET BACK TO EXPOSE 4-6 INCHES OF THE INSULATED LEADS. STRIP THE INDIVIDUAL WIRE LEAD ENDS FOR THE CONNECTION. (EXPOSE ABOUT 3/4" OF BARE WIRE.) THEN TIGHTEN UP ON THE CABLE. DO NOT OVERTIGHTEN! THIS COULD RESULT IN PINCHING THROUGH THE PLASTIC WIRE INSULATION AND CAUSE A SHORT OR "HOT" WIRES. (YOU COULD GET SHOCKED.) THE CLAMP IS INTENDED FOR STRAIN RELIEF OF THE WIRES, AND SLIGHT PRESSURE IS USUALLY SUFFICIENT TO ACCOMPLISH THIS.



IF INSULATED CABLE IS NOT AVAILABLE, APPROPRIATE STRAIN RELIEF CONNECTORS OR CLAMPS SHOULD BE USED. THERE SHOULD BE NO CLAMPING OR PINCHING APPLIED TO THE INDIVIDUAL SUPPLY LEADS.

4 Connect the power line to the black, white and ground wires found in the junction box using three wire connectors. CAUTION! - Connect black wire to black wire, white wire to white wire and ground wire to ground wire (green to bare copper). Using UL approved electrician's tape, secure the wire connectors in a workmanlike manner (See Figure 6).

5 Tighten the strain relief clamp to secure the supply wire. DO NOT OVERTIGHTEN (See Figure 7). Reinstall the junction box cover.

STEP 4 - COMPLETING THE INSTALLATION

To complete the installation and system checkout requirements, the following steps must be performed.

- 1** Check the thermostat probe position. Make sure the thermostat probe is routed through the holding guide and is not touching any metal surface.
- 2** Make sure the arm for the automatic air sweep function and the filters are properly positioned in the ceiling grille.
- 3** Secure the ceiling grille to the ceiling panel with 4 screws.
- 4** Turn on the power supply to the roof top air conditioner.

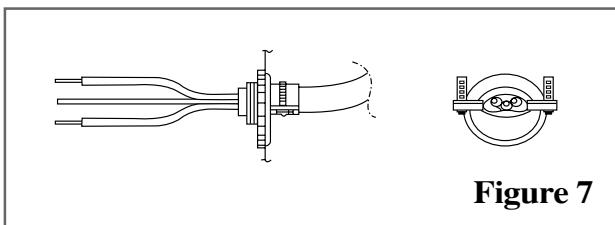

TROUBLE SHOOTING GUIDE

If you have problems with your recreation vehicle air conditioner, check this guide before contacting your service representative.

TROUBLE	POSSIBLE CAUSES	SOLUTION
THE UNIT DOES NOT START	The unit may not be connected to the power supply correctly.	Check the power supply of the vehicle and make sure it is provided correctly.
THE UNIT IS NOT COOLING THE ROOM	There could be blockage of unit's air output.	Make sure that there are no obstacles restricting or blocking the unit's output.
	The roof top air conditioner is not level.	Mount the roof top air conditioner as level as possible from front to rear and side to side when the vehicle is parked. Make sure that the mounting of the air conditioner is correct and level.
	The temperature setting is too high.	Reset the Air V to a lower temperature setting.
	The air filter is dirty.	Remove and clean the filter.
	The room was already very hot before the unit was turned on.	Allow a sufficient amount of time for unit to cool the room.
THE UNIT IS MAKING NOISES	The unit is clicking and gurgling.	These noises are normal during the operation of the unit.
THE UNIT HAS WATER DRIPPING INSIDE	The basepan gasket has not been evenly compressed to about 60%.	Mounting bolts should be tightened evenly by compressing the basepan gasket to the sixty percent requirement.
THE UNIT HAS ICE OR FROST ON THE COILS	The temperature is low inside.	Adjust the thermostat control knob to a warmer setting. Should frosting continue, operate on LOW or HIGH FAN setting until the cooling coil is free of frost.
	The filter is dirty.	Remove and clean the filter.

NORMAL MAINTENANCE PROCEDURES

ACTIVITY

Remove cover and wash the condenser coil

Remove cover and clean the water drains

Clean the filters*

*Generally, filters should be cleaned every 30 days.

The filters are very efficient in removing airborne particles.

More frequent cleaning may be necessary depending on the air quality.

FREQUENCY

Twice a year

Yearly

Once a month

How to Remove the Filters:

Remove the air filters by pulling them as illustrated below.

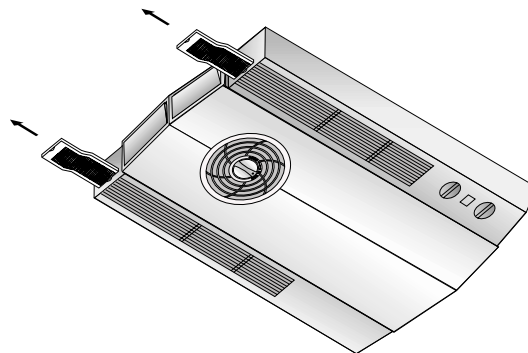

How to Clean the Air Filters:

Wash away dust from the air filters with clean water or vacuum the filters with an electric household vacuum cleaner.

PART DIAGRAM

UPPER UNIT

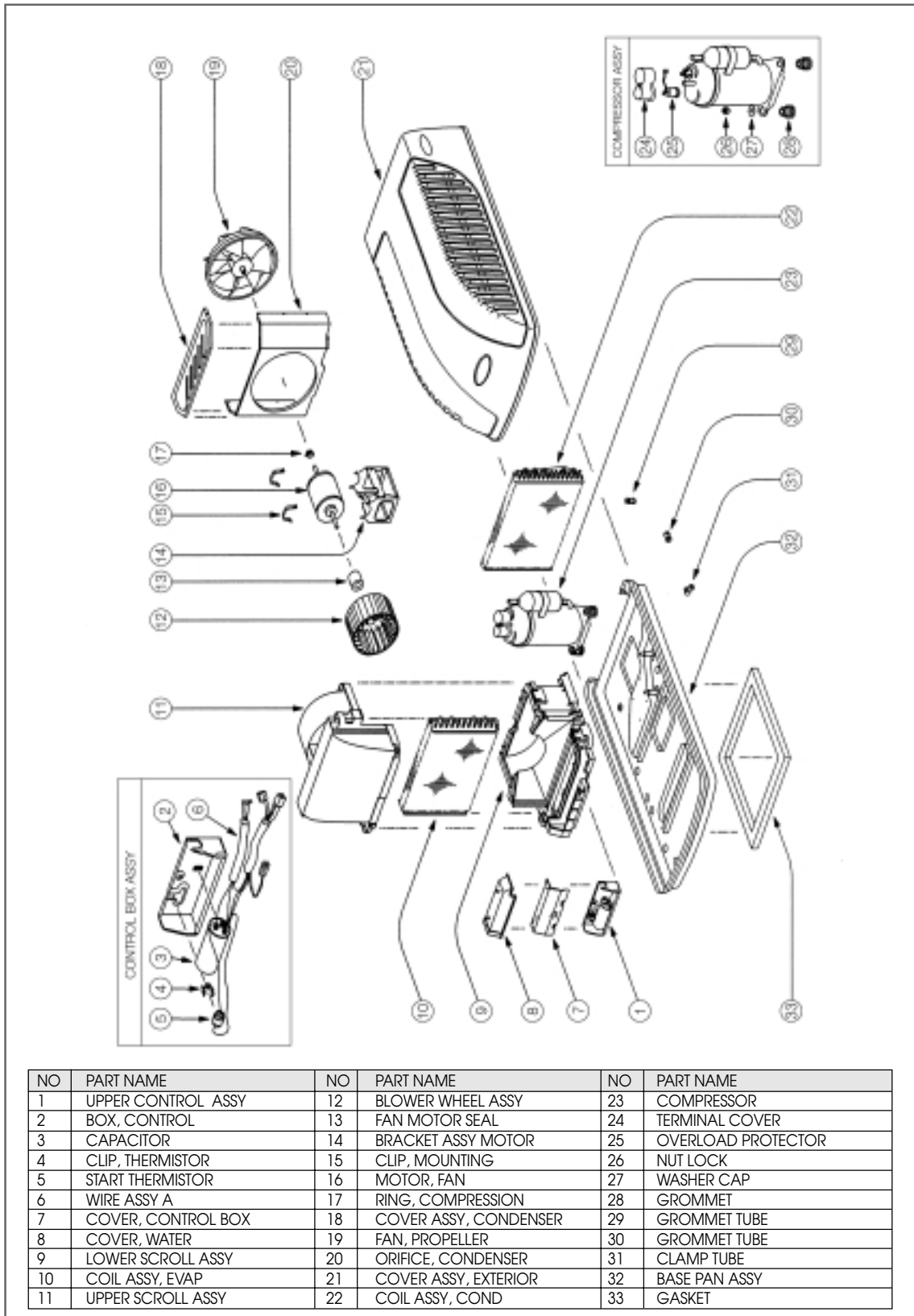

NO	PART NAME	NO	PART NAME	NO	PART NAME
1	UPPER CONTROL ASSY	12	BLOWER WHEEL ASSY	23	COMPRESSOR
2	BOX, CONTROL	13	FAN MOTOR SEAL	24	TERMINAL COVER
3	CAPACITOR	14	BRACKET ASSY MOTOR	25	OVERLOAD PROTECTOR
4	CLIP, THERMISTOR	15	CLIP, MOUNTING	26	NUT LOCK
5	START THERMISTOR	16	MOTOR, FAN	27	WASHER CAP
6	WIRE ASSY A	17	RING, COMPRESSION	28	GROMMET
7	COVER, CONTROL BOX	18	COVER ASSY, CONDENSER	29	GROMMET TUBE
8	COVER, WATER	19	FAN, PROPELLER	30	GROMMET TUBE
9	LOWER SCROLL ASSY	20	ORIFICE, CONDENSER	31	CLAMP TUBE
10	COIL ASSY, EVAP	21	COVER ASSY, EXTERIOR	32	BASE PAN ASSY
11	UPPER SCROLL ASSY	22	COIL ASSY, COND	33	GASKET

CEILING UNIT

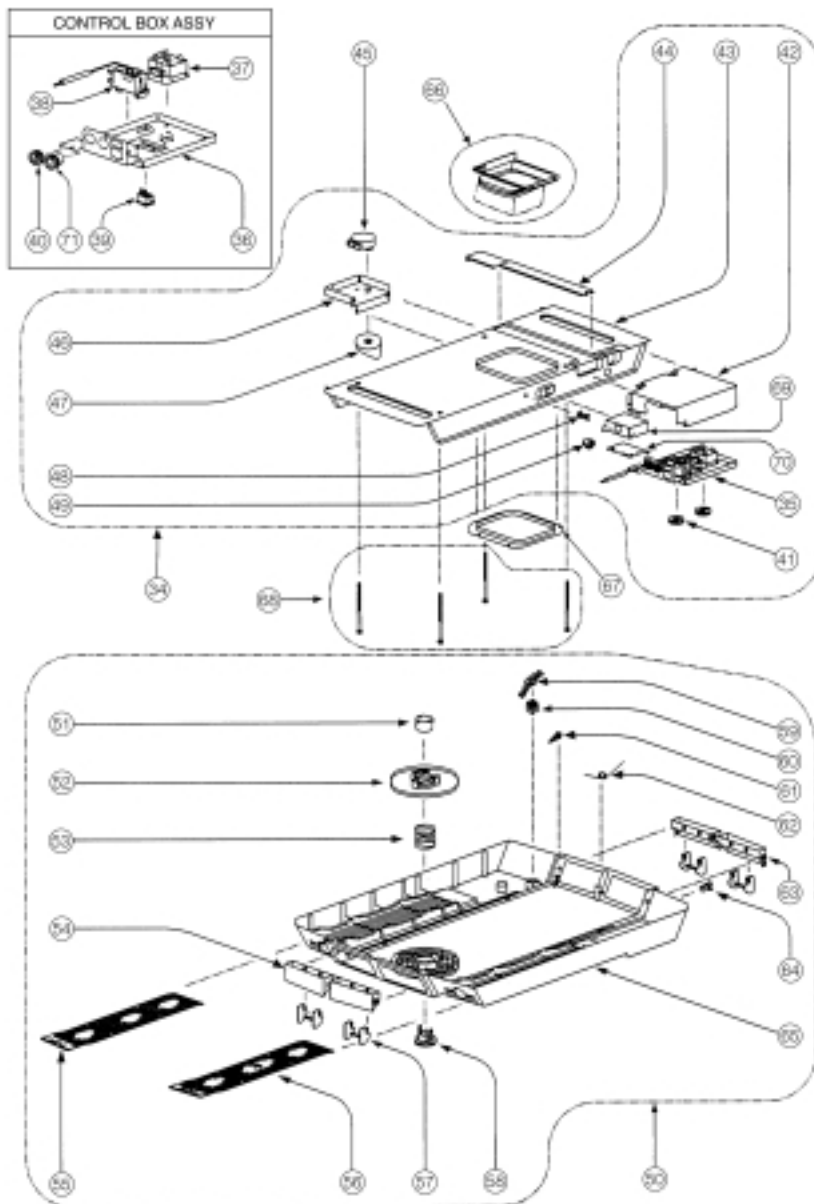

NO	PART NAME	NO	PART NAME	NO	PART NAME
34	PANEL ASSY, CEILING	47	CAM	60	BRACKET LINK
35	CONTROL ASSY, CEILING	48	WIRE STANDOFF	61	ARM
36	CONTROL BOX 2	49	RELIEF, STRAIN	62	SPRING LINK
37	ROTARY SWITCH (MASTER CONTROL)	50	GRILLE ASSY, CEILING	63	BLADE HORIZONTAL, REAR
38	THERMOSTAT	51	BRACKET, DOOR	64	LATCH, PUSH
39	ROCKER SWITCH	52	DIFFUSER DOOR ASSY	65	INSU ASSY, CEILING GRILLE
40	GROMMET, NEOPRENE	53	SPRING, DOOR	66	DUCT ASSY
41	KNOB ASSY	54	BLADE HORIZONTAL, FRONT	67	DUCT PLATE
42	COVER CONTROL BOX 2	55	FILTER ASSY, LEFT	68	MOUNTING BOLT
43	INSU ASSY, CEILING PANEL	56	FILTER ASSY, RIGHT	69	JUNCTION BOX
44	GUARD ASSY, WIRE	57	BLADE, VERTICAL	70	COVER, JUNCTION BOX
45	MOTOR, AIR SWEEP	58	HANDLE, DOOR	71	CORD PUSH
46	BRACKET, AIR SWEEP MOTOR	59	LINK		



TRANSICOLD
A/C INDUSTRIES

Subsidiary of Carrier Corporation

P/N:71RC6A5415G

OWNER'S GUIDE

OPERATION & INSTALLATION



Air V

CARRIER RECREATIONAL VEHICLE AIR CONDITIONER

PRODUCT INFORMATION

Model Number _____

Date in Service _____

Unit Serial Number _____

Ceiling Assembly Serial Number _____

INSTALLER

Date of Installation _____

Name _____

Address _____

Phone _____